

# ATK SERIES

## TUCK-A-WAY TAIL LIFTS

Perfection in every detail



- **Less weight - more payload**
- **Easy & quick installation**
- **Long life - low maintenance**

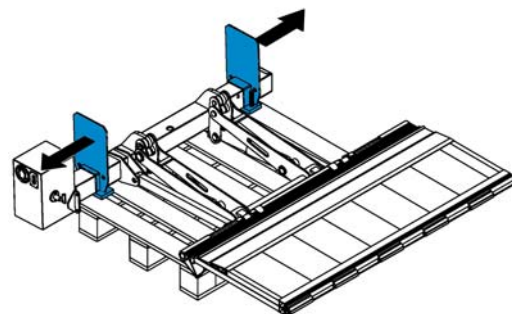

AHT's ATK series of tail lifts consists of a superior and cost effective two cylinder system. Cylinders are mounted inside the lift arms and ensure the stable operation of the platform, even with an uncentred load.

All models are completely assembled, adjusted and tested before leaving the factory. Mounting brackets that simply slide into place enable effortless installation without the need for any welding.

**Gough Transport  
Solutions**

'QUALITY HYDRAULIC & TRANSPORT EQUIPMENT'



Part No.	Model	Mechanism	Platform	Capacity kg	Load centre mm	Platform Size W x L mm	Weight kg
ATK50010*	ATK-500ST/ST	Steel	Steel	500	500	1525 x 940	212
ATK50030*	ATK-500ST/AL	Steel	Aluminium	500	500	1525 x 940	173
ATK50050*	ATK-500AL/AL	Aluminium	Aluminium	500	500	1525 x 940	135
ATK75010*	ATK-750ST/ST	Steel	Steel	750	500	1800 x 940	236
ATK75030*	ATK-750ST/AL	Steel	Aluminium	750	500	1800 x 1200	203
ATK75050*	ATK-750AL/AL	Aluminium	Aluminium	750	500	1800 x 1200	145
ATK100030*	ATK-1000ST/AL	Steel	Aluminium	1000	500	2000 x 1150	247
ATK100050*	ATK-1000AL/AL	Aluminium	Aluminium	1000	500	2000 x 1150	183

\*1=12V 2=24V

## Standard Inclusions

- Two cables for direct +/- powerpack connection to battery



Hand control

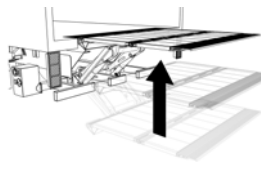

Mechanical auto levelling



Platform security

## Optional

- Added platform length
- 3-Button foot control
- Flashing lights
- Additional hand control

# Why AHT is the number 1 sold tail lift in Australia

## Safety First

Cylinders are equipped with mechanical hose-burst valves which are operative during lifting and lowering the platform. The platform will stop immediately if a hose bursts, protecting operator and goods alike.



## Cylinders

AHT's all-aluminium cylinders are more powerful and weigh less. They have been tested to 800,000 cycles without changing seals and are noiseless in operation at all temperature ranges. Their ceramic-coated pistons, and high resistance to salt water and other corrosive substances, ensure a long life span.



## Powerpack

Platform lift is achieved by the compact and fully integrated powerpack. Its two-button remote control, for Up and Down operation, is equipped with a cord pull-out protector to prevent electrical shorts and other damage.



## Load centres

Increased load centres mean the rated capacity of the tail lift is effective at a greater distance, providing more versatility over a range of load types. AHT offers the largest load centres available on the market.

